

ATOS Core

Optical 3D Scanner for Quality Control



Optical 3D Metrology

For Industrial Use

Optical 3D coordinate measuring machines capture detailed and easily interpretable quality information in a short measuring time. They provide fully automated full-field deviations between the actual 3D coordinates and the CAD data. As this measuring data contains all the object information, in addition to the surface deviations from the CAD, the software also automatically derives detailed information such as GD&T, trimming or hole positions.

GOM's measuring systems ensure the dimensional quality in particular of sheet metal, casting and plastics products in the automotive, aerospace or consumer goods industries. They form the basis for the optimization of production and machine parameters as part of a value-added measuring procedure.

Measuring Room and Production

In the measuring room, the measurement technician creates the measuring programs and the evaluation templates offline on the computer in a CAD-like environment for a wide range of different parts. After the scanning process, the evaluation templates are filled with the full-field 3D coordinates and the reports are generated.

In the production department, the measurement takes place directly on site. There is no need to carry the object to a measuring room. Robustness, measuring speed and compensation for temperature fluctuations are convincing factors of the scanners, enabling traceable results to be captured even under harsh conditions.





ATOS Core

Optical 3D Scanner for Quality Control

ATOS Core is the specialist for three-dimensional measurement of small components up to 500 millimeters in size. It generates high-quality 3D data for applications such as reverse engineering and rapid prototyping in design and product development and enables efficient quality control in the production process.

The sensor forms the basis for a diverse range of measuring tasks – from simple 3D scanning to fully automated measurement and inspection processes. ATOS Core is used for the measurement of small and medium-sized objects, such as ceramic cores and cast or plastic parts.



ATOS Technology

High Tech in Robust Machines

Optics and electronics are integrated in a very small installation space. Its compact shape gives the sensor high stability and allows measurements to be taken in confined spaces. Depending on resolution requirements and measuring area sizes, the easy-to-handle sensor heads can be replaced easily via a quick release, without the need for recalibration.

Triple Scan Principle

Together with both cameras, the projection unit operates according to the Triple Scan Principle. During the measurement, precise fringe patterns are projected onto the surface of the object and are recorded by two cameras and the projector unit. Thus, 3D surface points from three different ray intersections can be calculated.

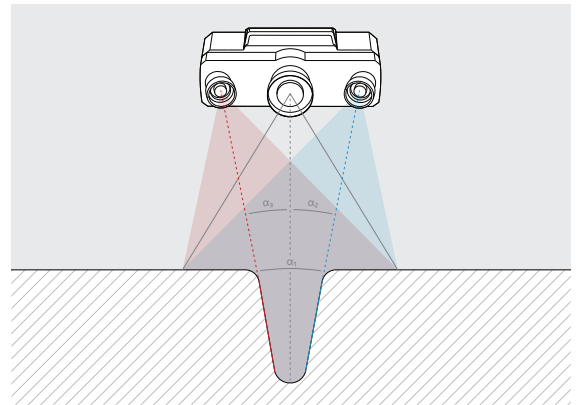

Blue Light Technology

The projection unit of the ATOS Triple Scan system is based on Blue Light Technology. Since the sensor works with narrowband blue light, interfering ambient light can be filtered during image acquisition. Due to its powerful light source, short measuring times can be achieved.

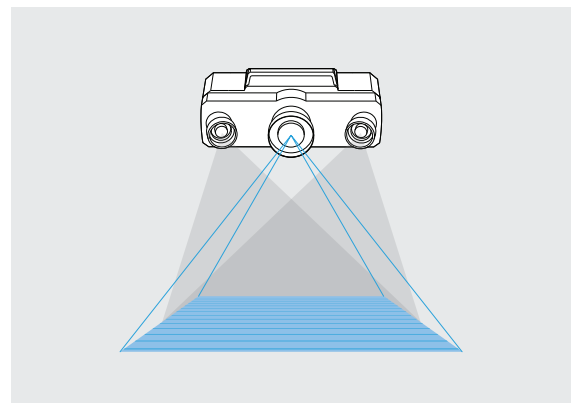

Self-Monitoring System

The sensor recognizes changing ambient conditions during operation and can compensate these changes. To ensure the quality of the measuring data, the software of the sensor is continuously monitoring the calibration status, the transformation accuracy, environmental changes and part movements.

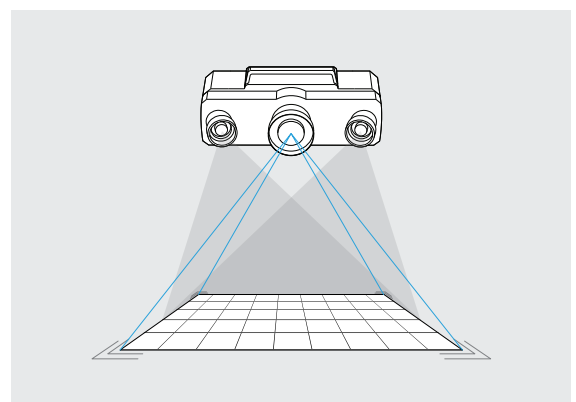

ATOS Core Workflow

Simple and Efficient

ATOS Core is an optical 3D scanner based on fringe projection, delivering accurate and traceable 3D coordinates. Below is a basic three-step workflow showing how to measure with ATOS Core.

Measurement

Measure your object manually or automatically

No complicated setup necessary



Inspection & Evaluation

From 3D point clouds to polygon meshes

Compare actual scan data with technical drawings or CAD



Results & Reports

Customizable reports with intuitive presentations

Export according to available data standards

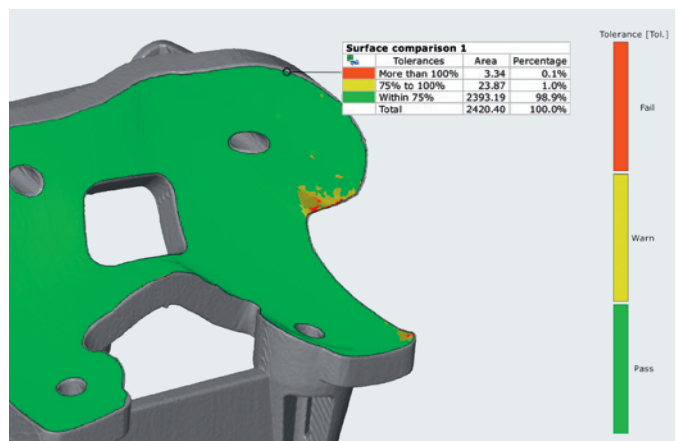

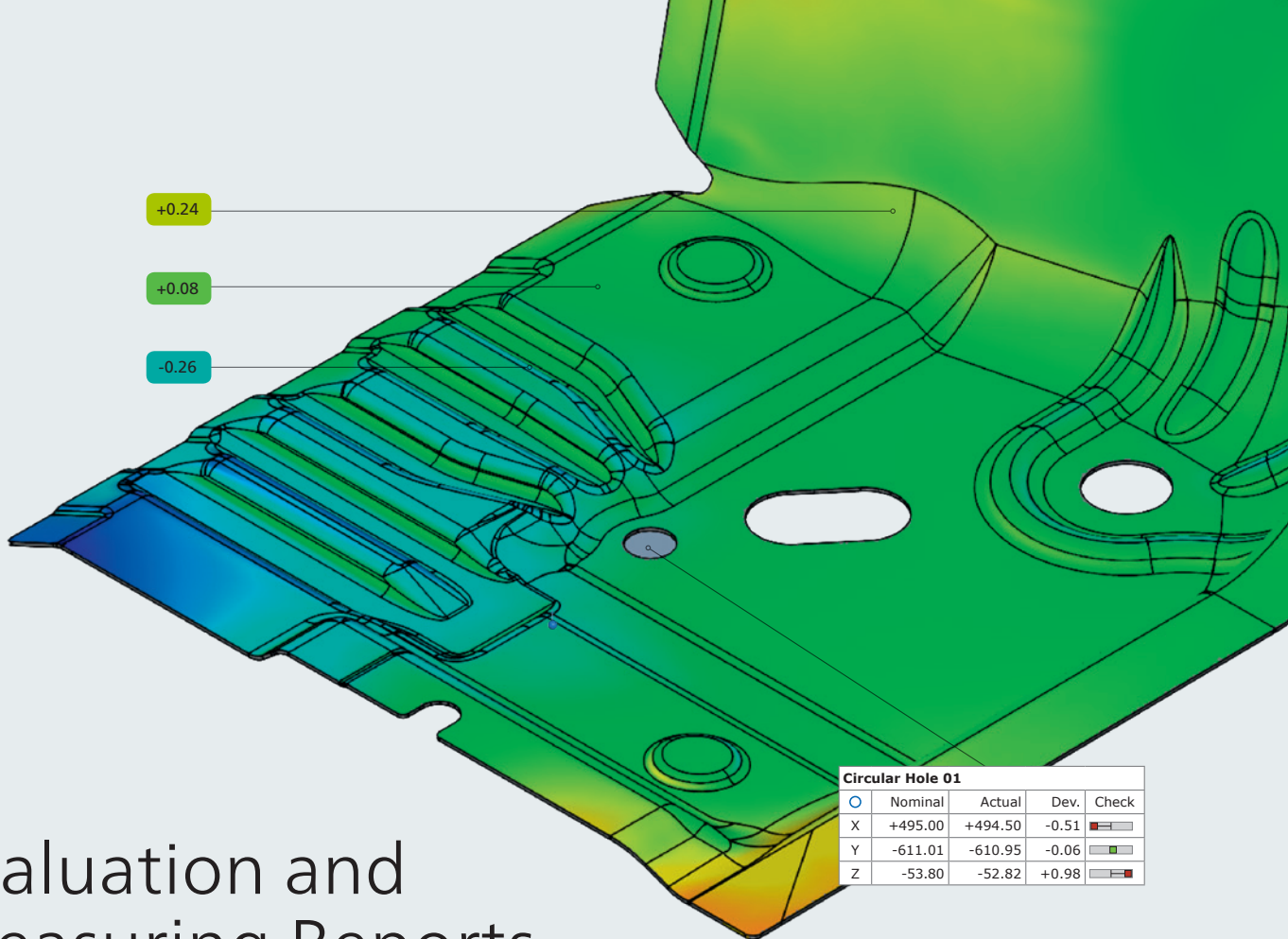

Evaluation and Measuring Reports

GOM Inspect Software

Certified Inspection Software

To ensure precise measuring accuracy, the GOM software packages have been tested and certified by the two institutes PTB and NIST. The accuracy of the evaluation software is tested by comparing the results from the software with the reference results. The GOM software has been placed in category 1, the category with the smallest measurement deviations.

Nominal-actual comparison – The calculated polygon mesh describes freeform surfaces and standard geometries. These can be compared with the drawing or directly with the CAD data set with the help of a surface comparison. A 3D analysis of surfaces as well as a 2D analysis of sections or points can be implemented in the software. CAD-based generation of standard geometries such as lines, planes, circles or cylinders is also possible.

Teaching by Doing – With Teaching by Doing, any completed evaluation can be easily applied to two or more parts. Thanks to the parametric design, the software automatically stores each individual inspection step. There is no difference between single and multiple evaluations. All evaluation steps can be operated without scripting, previous planning or user intervention, so that no time is spent on programming.

GD&T analysis – In contrast to the pure dimension analysis, the GD&T analysis focuses on the functional aspect of the part. Corresponding GD&T elements are, for example, planarity, parallelism or cylindricity. Both, a standardized analysis of 2-point distances and of the maximum material requirement as well as the position tolerance in local datum and coordinate systems are possible.

Reporting – The reporting module enables users to create result reports containing snapshots, images, tables, diagrams, text and graphics. The results can be visualized and edited in the user interface as well as exported to a PDF document. Templates are reusable and each scene saved in a report can be restored in the 3D window.

Industrial Applications

GOM Provides Complete Solution

ATOS Core is used in the manufacturing process of the automotive, aerospace, consumer goods and medical industries as well as for research institutes and universities.

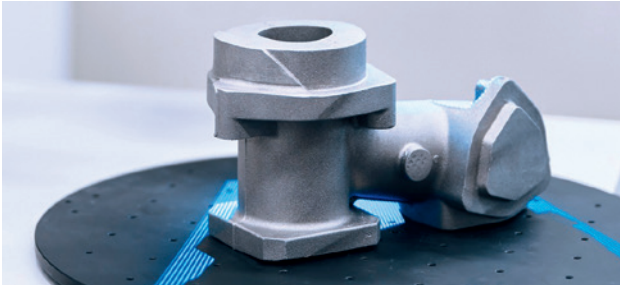

Casting & Forging – ATOS Core shortens the measuring and inspection times in sand, pressure die and investment casting as well as in the forging industry.



Plastics – ATOS Core accelerates nearly all areas of injection molding, thermoplastic molding and blow molding process chains.

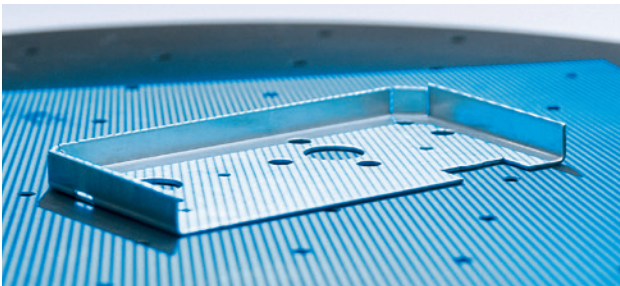

Metal Forming – ATOS Core accelerates metal forming processes and ensures a comprehensive quality control ranging from toolmaking and try-out, first article inspection and series inspection to assembly.

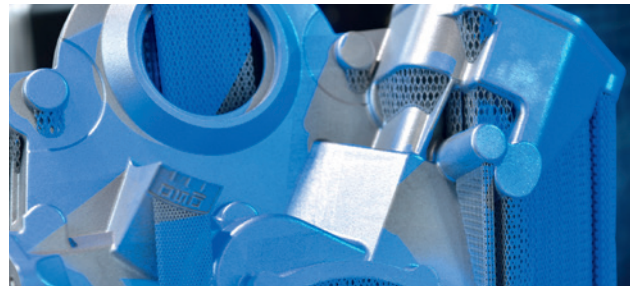

Additive Manufacturing – ATOS Core provides high-resolution polygon meshes (STL) for 3D printing, milling, additive manufacturing and dimensional verification.

Technical Data

	ATOS Core 45	ATOS Core 80	ATOS Core 135	ATOS Core 200	ATOS Core 185	ATOS Core 300	ATOS Core 500
Measuring area [mm]	45×30	80×60	135×100	200×150	185×140 mm	300×230 mm	500×380 mm
Working distance [mm]	170	170	170	250	440	440	440
Sensor dimensions [mm]	206×205×64				361×205×64		
Weight [kg]	2.1				2.9		
Temperature range	+5 °C to +40 °C, non-condensing						

Depending on the resolution and the size of the measuring area, permanently preset sensor models can be replaced quickly and reliably according to the hot-plugging principle.



Automated 3D Metrology

GOM ScanCobot – A Perfect Match for ATOS Core

Integrated into the GOM ScanCobot, ATOS Core offers a quick start into the automated metrology world. GOM ScanCobot combines a 3D sensor with a collaborative robot and a rotation table, forming a mobile automated solution with a very small footprint. The virtual measuring room (VMR) in the

GOM Inspect software enables measurements to be simulated and planned before real measurement. GOM ScanCobot is a flexible, easy-to-set-up automation system for efficient quality control of small and medium-sized parts.

Technical Data

Dimensions footprint [mm]	975 x 775
Working height [mm]	1000
Power supply	standard, 100–240 V (1-phase, 16A)
Max. part size [diameter in mm]	500
Max. part weight [kg]	50





GOM

Precise Industrial 3D Metrology

GOM, a company of the ZEISS Group, specializes in industrial 3D coordinate measuring technology, 3D computed tomography as well as 3D testing and supports customers worldwide providing machines and systems for manual and automated 3D digitization, evaluation software, training and professional support from a single source.

Today, more than 17,000 system installations improve product quality and accelerate product development and manufacturing processes for international companies in the automotive, aerospace and consumer goods industries, their suppliers as well as many research institutes and universities.

Worldwide Competence

The worldwide GOM Metrology Network comprises more than 60 sites on five continents. The research and development, production, communication and administration departments are located at the headquarters in Braunschweig. In the research and development departments, engineers, mathematicians and scientists work on the measuring technology of the present and the future.

The certified partners of the network represent GOM worldwide. With more than 1,200 metrology experts, the GOM Metrology Network provides profound advice as well as professional support and service to operators

on site in their local languages. At three GOM hubs in Europe, Asia and America, GOM service experts give advice to the partner network and global customers.



Holistic Technology Partner

Numerous services and training courses support the users with their daily work when using 3D measurement technology. Training courses and webinars deepen the knowledge about the software and show further application fields of the measuring systems.

The online portal provides instructions, tutorials and frequently asked questions and answers for the user. Furthermore, there is an application forum for exchanging ideas and supporting each other.

At conferences and application-based workshops, GOM directly shares knowledge on processes and measurement technology. The new GOM Care offer combines support and service for 3D measuring systems from GOM on a contractual basis.



GOM Care

With GOM Care, GOM offers fast and reliable customer support and services when necessary. The GOM Care support and services is based on three pillars: Remote Assistance, Services and Contract Plans.



GOM Training

The GOM training concept is based on practice-oriented training courses for different levels: basic and advanced training as well as expert courses. The modules can be combined and are based on each other.

